



- SE/WR-CD-TYPE
- SE/WR-S-TYPE
- SE/WR-DC-TYPE



SOUTHEAST MACHINERY

PLASTIC WASTE RECYCLING MACHINE

SE/WR-DC-TYPE

- HIGH EFFICIENCY SCREEN CHANGE EQUIPMENT CONTROLLED BY OIL HYDRAULIC TO EXCHANGE THE TWO FILTERS WITHOUT STOPPING MACHINE.
- THE MOTOR IS CONTROLLED BY INVERTER. THE MOTOR WITH INVERTER CAN BE ADJUSTED THE SPEED AND IT'S STABILITY AND LOW POWER CONSUMPTION IS BETTER THAN V.S. MOTOR.
- IT IS EQUIPPED WITH VACUUM VENT TANK WITH WASTE WATER DISPOSAL TANK WHICH TAKE THE GAS OFF PROMPTLY AND DEHYDRATE THOROUGHLY TO GET CLEANER PELLETS.
- IT IS CONVENIENT TO KEEP THE MACHINE LIFE AS WELL AS MAINTENANCE.

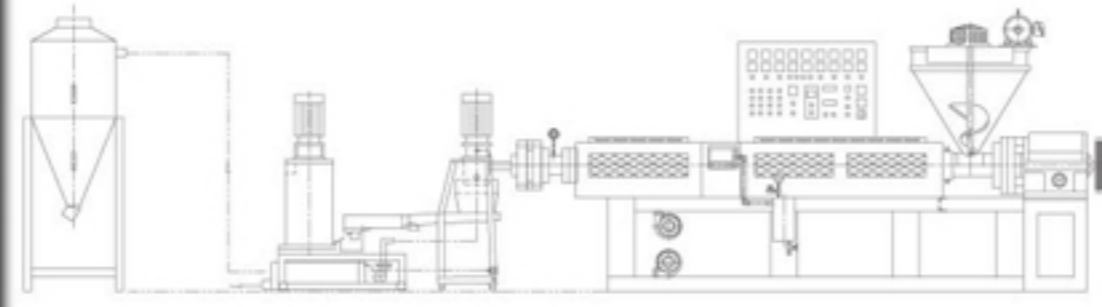
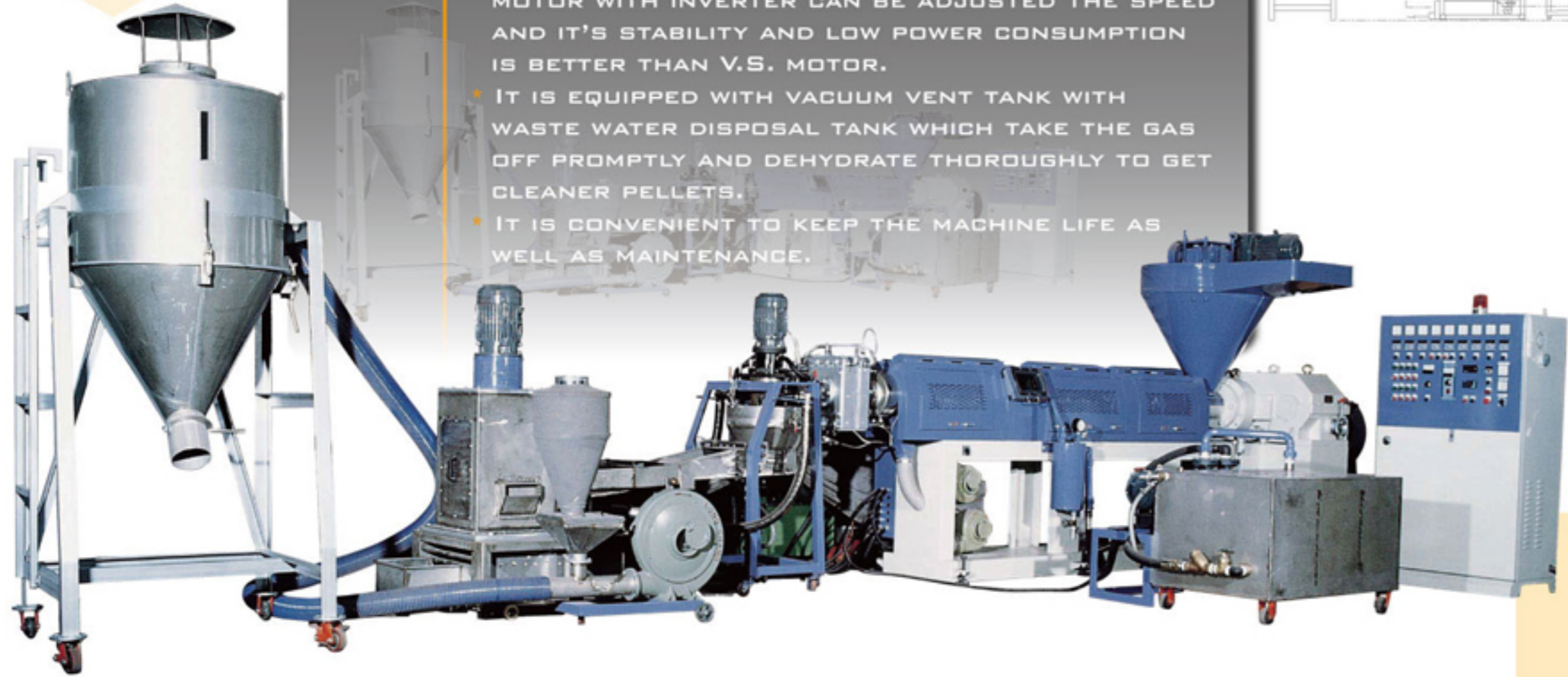

SE/WR-S-TYPE

- THIS MODEL IS FOR RECYCLING VARIOUS MATERIALS AND DYEING.
- IT HAS OPTIONAL VACUUM VENT TANK WITH WASTE WATER DISPOSAL TANK WHICH CAN TAKE THE GAS, OR INK OFF PROMPT AND DEHYDRATE THOROUGHLY TO HAVE CLEANER PELLETS.
- THE WASTE WATER DISPOSAL TANK CAN MAKE PRODUCTS CLEANER AND WILL NOT POLLUTE THE AIR.
- THE OPTIONAL DEHUMIDIFYING UNIT CAN MAKE THE PELLETS DRYER.

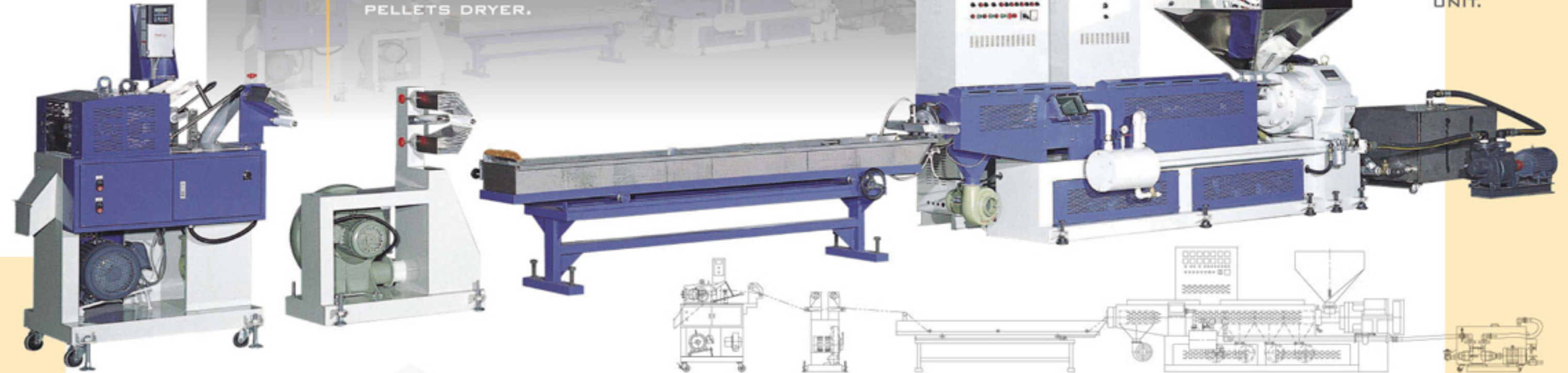

• VACUUM TANK.

• WASTE WATER DISPOSAL TANK.

• DEHUMIDIFYING UNIT.

SE/WR-CD-TYPE

- THIS MODEL IS TWO STAGE TYPE WHICH USES OIL HYDRAULIC SCREEN CHANGER TO CHANGE THE FILTER MORE EASILY AND PROMPTLY.
- THE MAIN DIE MOULD HAS A SPECIAL DESIGN TO GET THE VENT EFFECT AND LET THE MELTED RESIN DROPS SMOOTHLY INTO THE HOPPER.
- IT EQUIPPED WITH A FORCE FEEDING HOPPER TO ENSURE THE CRUSHED FILMS DROPS STABLY INTO THE BARREL.
- IF WE DON'T HAVE BUDGET FOR CRUSHER, WE CAN CHOOSE SIDE FEEDING HOPPER TO HELP US ACHIEVING FEEDING PERFECTLY.

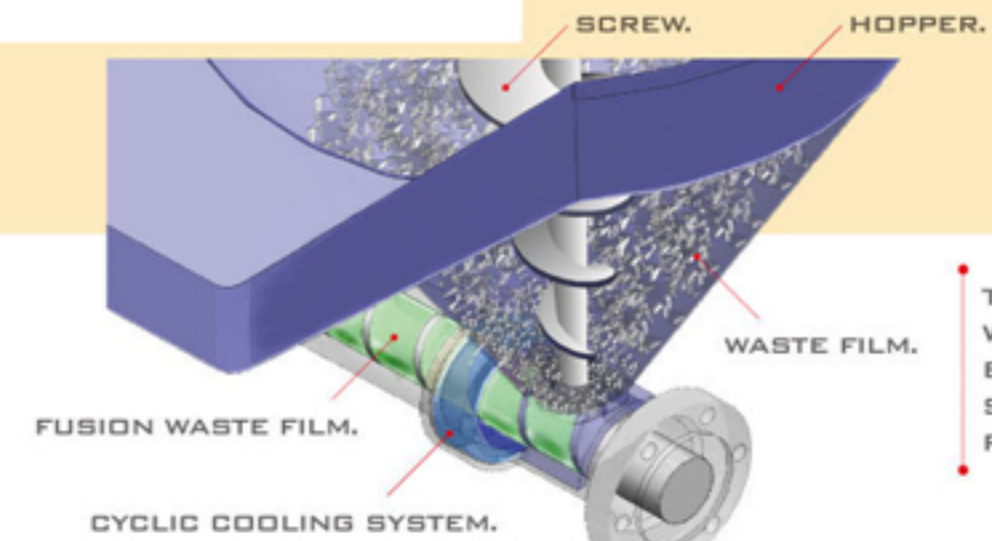

THE SITUATION IS DESCRIBED WITH THE WASTE FILM ARE ENTERED INTO BARRAL BY SCREW OF FORCED FEEDING HOPPER.

• WINDOW OF FORCED FEEDING HOPPER.

• HYDRAULIC SCREEN CHANGE MOULD.

• SIDE PUTTING FEEDING HOPPER.

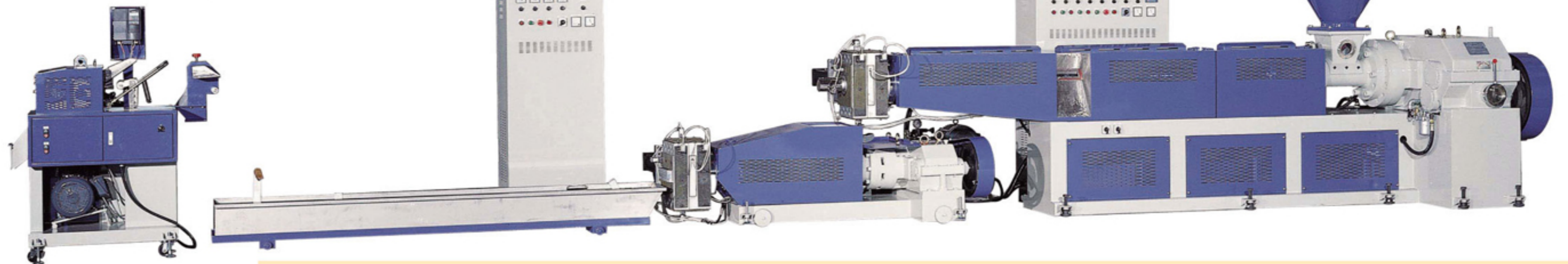
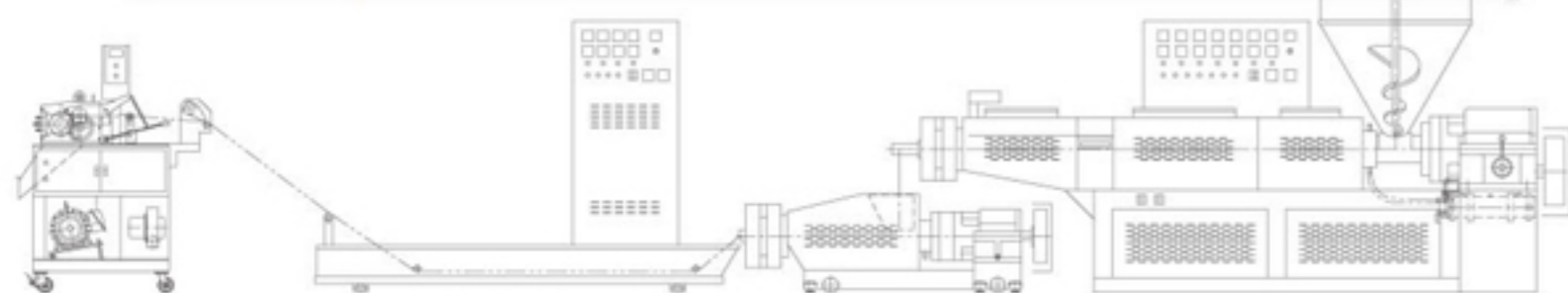

MODEL	SE/WR-85CD		SE/WR-100CD		SE/WR-120CD	
MATERIAL	PP, PE FILM		PP, PE FILM		PP, PE FILM	
OUTPUT	100-150 KG/HR		150-200 KG/HR		250-300 KG/HR	
EXTRUDER	MAIN	VICE	MAIN	VICE	MAIN	VICE
DRIVE MOTOR	40 HP	20 HP+INVERTER	60 HP	30 HP+INVERTER	100 HP	40 HP+INVERTER
SPEED RANGE	2 STEPS	STEPLESS	2 STEPS	STEPLESS	2 STEPS	STEPLESS
SCREW DIAMETER	85MM	85MM	100 MM	100 MM	120 MM	120 MM
L/D RATIO	32	10/1	32	10/1	32	10/1
HEAT CAPACITY	50 KW	25 KW	70 KW	35 KW	90 KW	45 KW
TEMP. CONTROL	6 ZONEs	3 ZONES	7 ZONEs	3 ZONES	8 ZONEs	4 ZONES
VENT EQUIPMENT	1 SET	NON	1 SET	NON	1 SET	NON
DIE	USE HYDRAULIC SCREEN CHANGE					
COOLING UNIT	2000x355x250 MM		2800x355x250 MM		3000x395x250 MM	
CUTTING UNIT	3 HP+INVERTER		5 HP+INVERTER		7 1/2 HP+INVERTER	
FORCE FEEDING HOPPER	5HP+INVERTER		5HP+INVERTER		5HP+INVERTER	
FLOOR DIAMENSION	10x2.1x2.21 M		11.5x2.2x2.35 M		12.5x2.3x2.35 M	
MACHINE WEIGHT	4500KGS		6500 KGS		8500 KGS	

SPECIFICATIONS ARE SUBJECT TO CHANGE WITHOUT NOTICE FOR IMPROVEMENT.

MODEL	SE/WR-85S	SE/WR-100S	SE/WR-120S
MATERIAL	PS/PC/ABS/475 SCRAP	PS/PC/ABS/475 SCRAP	PS/PC/ABS/475 SCRAP
OUTPUT	200 KG/HR	300 KG/HR	400 KG/HR
EXTRUDER	SINGLE	SINGLE	SINGLE
DRIVE MOTOR	50 HP+INVERTER	75 HP+INVERTER	125 HP+INVERTER
SPEED RANGE	STEPLESS	STEPLESS	STEPLESS
SCREW DIAMETER	85MM	100 MM	120 MM
L/D RATIO	32	32	32
HEAT CAPACITY	50 KW	70 KW	90 KW
TEMP. CONTROL	6 ZONEs	7ZONEs	8 ZONEs
VENT EQUIPMENT	1 SET	1 SET	1 SET
DIE	MANUAL SCREEN CHANGE		
COOLING UNIT	WATER BATH (STAINLESS STEEL)		
CUTTING UNIT	5 HP+INVERTER	5 HP+INVERTER	7 1/2 HP+INVERTER
FORCE FEEDING HOPPER	5HP+INVERTER	5HP+INVERTER	5HP+INVERTER
FLOOR DIAMENSION	8.8x2.1x2.3M	9.8x2.2x2.35 M	10.8x2.3x2.35 M
MACHINE WEIGHT	3400KGS	4500 KGS	6000 KGS

OPTIONAL : 1. VACUUM TANK 2. WASTE DISPOSAL TANK 3. DEHUMIDIFYING UNIT

SPECIFICATIONS ARE SUBJECT TO CHANGE WITHOUT NOTICE FOR IMPROVEMENT.

MODEL	SE/WR-100DC	SE/WR-120DC
MATERIAL	PP, PE FILM	PP, PE FILM
OUTPUT	150-200 KG/HR	250-350 KG/HR
EXTRUDER	SINGLE	SINGLE
DRIVE MOTOR	60 HP+INVERTER	125 HP+INVERTER
SPEED RANGE	STEPLESS	STEPLESS
SCREW DIAMETER	100 MM	120 MM
L/D RATIO	34	34
HEAT CAPACITY	70 KW	90 KW
TEMP. CONTROL	9 ZONES	10 ZONES
VENT EQUIPMENT	1 SET	BHGF12
DIE	TYPE : DOWNWARD CUT TYPE MOTOR : 3 HP AC+INVERTER SCREEN CHANGE : HYDRAULIC SCREEN CHANGE CUTTER : 3 PCS. SUS # 304	TYPE : DOWNWARD CUT TYPE MOTOR : 3 HP AC+INVERTER SCREEN CHANGE : HYDRAULIC SCREEN CHANGE CUTTER : 3 PCS. SUS # 304
DEHYDRATION UNIT	MOTOR : 5 HP AC+3 HP PUMP DEHYDRATOR : VERTICAL TYPE MATERIAL : STAINLESS STEEL SUS #304	MOTOR : 5 HP AC+3 HP PUMP DEHYDRATOR : VERTICAL TYPE MATERIAL : STAINLESS STEEL SUS #304
STORAGE TANK	DELIVERY UNIT : 3 HP BLOWER CAPACITY : 300 L MATERIAL : STAINLESS STEEL SUS #304	DELIVERY UNIT : 5 HP BLOWER CAPACITY : 500 L MATERIAL : STAINLESS STEEL SUS #304
SIDE FORCE FEEDING HOPPER	MOTOR : 7.5HP+INVERTER CAPACITY : 2000 L WASTE STORAGE TANK	MOTOR : 7.5HP+INVERTER CAPACITY : 2000 L WASTE STORAGE TANK
FLOOR DIAMENSION	10.0x2.2x2.5 M	11.0x2.3x2.8 M
MACHINE WEIGHT	6500KGS	8000KGS



SOUTHEAST MACHINERY CO.,LTD. COMPANY PROFILE

SOUTHEAST MACHINERY BEGAN BY MAKING TWO-STAGE PELLETIZERS IN 1987 WITH ONLY FIVE EMPLOYEES AND NT\$1 MILLION IN CAPITAL. NOW WE EMPLOY 30 STAFFERS AND SPECIALIZE IN VARIOUS PLASTIC EXTRUDERS AND TURNKEY PLANTS.

BACKED BY 20 YEARS IN R&D, INNOVATION, AND TECHNOLOGICAL INTEGRATION, WE ARE FULLY CAPABLE OF SUPPLYING A RANGE OF PLASTIC-PROCESSING MACHINERY AND TURNKEY PLANTS THAT MAKE BUSINESS EASY AND MORE PROFITABLE FOR DISTRIBUTORS AND END-USERS. OUR MACHINES ARE SUPPLIED WITH PROFESSIONAL AFTER-SALES SERVICE AND ARE KNOWN FOR THEIR SUPERIOR-QUALITY, COST-EFFECTIVENESS AND HIGH EFFICIENCY.

CUSTOMER LOYALTY AT HOME AND OVERSEAS HAS HELPED US TO GROW STEADILY AND ACHIEVE SUCCESS GLOBALLY. TO ENHANCE OUR GLOBAL PRESENCE, WE ARE DEDICATED TO DEVELOP INNOVATIVE PRODUCTS, STREAMLINE EFFICIENCY, EXPAND FACTORY, AND UPGRADE MANAGEMENT, WITH THE ULTIMATE GOAL OF OFFERING THE BEST, COMPETITIVELY-PRICED MACHINERY FOR THE PLASTIC PROCESSING INDUSTRY.

OUR OTHER PRODUCTS

- HD/LD/LLDPE/PP BOWING FILM MAKING LINE
- PVC HEAT SHRINKABLE FILM MAKING LINE
- PVC PROFILE MAKING LINE
- PVC/PE/PP PIPE MAKING LINE
- PP DRINKING STRAW MAKING LINE
- PP PACKING TAPE MAKING LINE
- MANUFACTURE OF OTHER EXTRUSION MACHINERY
- ALL KINDS OF EXTRUSION TURN-KEY PLANT



鷹順塑膠機械股份有限公司

SOUTHEAST MACHINERY CO., LTD.

公司地址:74550台南縣安定鄉海寮村5之48號

NO.5-48 HAILIAO VILLAGE, ANDING SHIANG,

TAINAN HSIEN, TAIWAN R.O.C

TEL:886-6-5938640(REP)

FAX:886-6-5935351(SALES)

E-mail:se7966@ms17.hinet.net

www.southeast.com.tw